

Rapid TITAN-UV Handheld Sanitizer

Rapid Sanitizing of Countertops, Seating, Beds, Bedspreads, Food Cutting Tables, Day Care Toys, Hand Rails, Toilet Seats, Bathrooms, Gym Equipment, Kitchen Counters, Nurse Stations, Ambulances, Fire Departments, Restaurants, School Desks, Lockers, Spa Areas...

The Rapid **Titan-UV™** packages a multi-patented UVC technology in a versatile, hand-held device designed for decontamination of surfaces where microbes are an issue. Our Titan-UV is a significant adjunct to your standard cleaning program.

The user slowly passes the device closely over the contaminated surface area, allowing the energy from the very high output UVC Emitter to rapidly and effectively decontaminate surfaces. An aluminum safety shield prevents direct exposure to UVC energy, while also adding reflectance that increases the light's total effectiveness.

The **Titan-UV™** may be used in any type of residential, commercial, industrial or institutional building to provide a fast-acting, portable method of decontaminating tabletops, beds, public seating, walls and other surfaces.

APPLICATIONS

Titan-UV™ applications include laboratories, hospitals, food and beverage processing areas, schools, libraries and homes. The device is suitable for a variety of specialized uses, e.g.:

- Residential and commercial mold remediation (as a supplement to other control strategies)
- Food preparation, processing, restaurants, etc. to reduce contamination
- DNA laboratories to prevent cross-contamination
- Surface decontamination in hospitals, clinics
- Day Care Centers, schools, gyms, locker rooms

BENEFITS



- Kills or inactivates surface microorganisms that contribute to poor IAQ and/or the spread of infectious disease.
- Uses patented state-of-the-art solid-state electronic power supply for enhanced reliability and performance.
- Produces no ozone or other secondary contaminants – will not harm building occupants, equipment or furnishings.
- Portable, versatile and easy – just plug in and use. No installation required.
- Proven through independent testing to provide the highest output of any UVC handheld device on the market for most effective germicidal control.
- A must have for emergency contamination of surfaces due to vomiting, blood, feces or microbial spills in a laboratory,
- Inexpensive to operate – uses approximately the same energy as a 75-watt light bulb
- Long service life – typically 9000 hours between change outs.



IDEAL FOR HOSPITALS, CLINICS, SCHOOLS, FIRE DEPARTMENTS, GYMS, DAY CARE CENTERS, HOTELS, RESTAURANTS...

TITAN-UV™ SPECIFICATIONS

The UVC Emitter and fixture is factory assembled and tested. Titan-UV consists of a housing, power source, reflector, safety shield, six-foot power cord, easy-to-grip handle, Emitter sockets and Emitter.

The housing is constructed of 304 stainless steel. The reflector is constructed of heavy gauge, specular finished aluminum alloy with approximately 85% reflectance at 254nm wavelength. The safety shield is constructed with highly polished, heavy gauge aluminum to enhance the reflectance of the UVC energy. The six-foot power cord is UV-resistant. All components are in one integral assembly to maximize serviceability.

The power source is a Class P, electronic, rapid start type with a power factor greater than 0.95 and a power conversion of greater than 75%. The power supply design includes RF and EMI suppression. The power supply has been designed to maximize photon production, irradiance and

100% RH and up to 2000 fpm velocity. The fixture is currently available in 115 VAC, 50/60 Hertz, single phase.

The Emitter sockets are medium bi-pin, double click safety, twist lock type and are constructed of UVC-resistant polycarbonate.

The Emitter tube is a very high output, hot cathode, T5 diameter, medium bi-pin type that produces broadband UVC of 250-260 nm. Each tube produces the specified output at up to 2000 fpm velocity and air temperatures of 35-170° F. It produces no ozone or other secondary contaminants.

Independent testing: Unit has been tested by an independent test laboratory in accordance with the general provisions of IES Lighting Handbook, 1981 Applications Volume, and has been verified through independent testing to provide output per inch of glass of not less than 10 µW/cm² at 1 meter in a 400fpm airstream of 45° F.

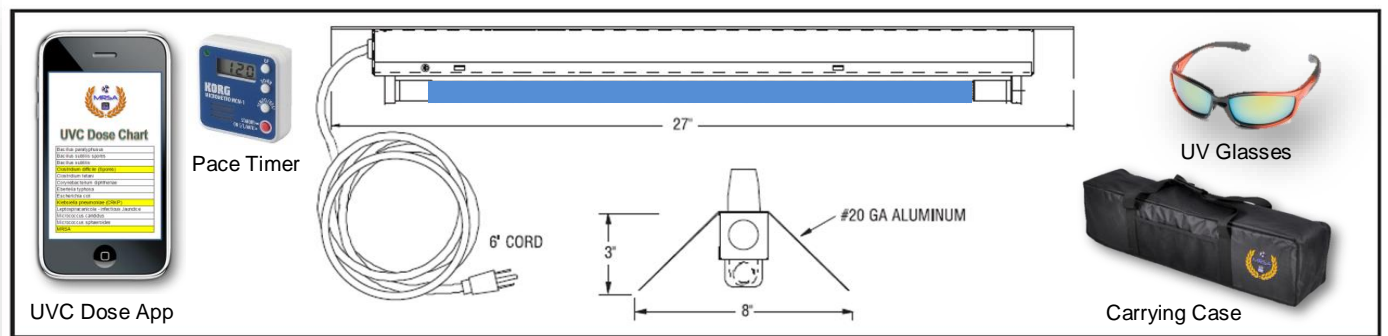

561-531-9398
WWW.MRSA-UV.COM